

**OPINION UNDER SECTION 74A**

Patent	<b>EP(UK) 1408284</b>
Proprietor(s)	Mr Mike Donnelly
Exclusive Licensee	
Requester	Mr Alan Wilson, on 25 November 2008
Observer(s)	
Date Opinion issued	10 February 2009

**The request**

1. The comptroller has been asked to issue an opinion on the validity of the claims of EP1408284 in light of the following documents:

GB1075334  
GB1238564  
DE2332594  
EP0290390  
GB328713  
GB2378750  
GB2332504  
US6318403  
GB2241286

**Observations**

2. Observations in reply were received from Murgitroyd and Company on 29<sup>th</sup> December 2008.

**Observations in reply**

3. Observations were received on 9<sup>th</sup> January 2009.

## **Background**

4. The patent (EP1408284) has already been subject to an earlier opinion as to whether it was infringed by a pipe cowl invented by Mr Richard Wragg and imported into the UK and distributed by Flowflex Holdings Limited.

## **Allowance of the request**

5. Of the documents listed above only US6318403 was considered in proceedings before the EPO but was not considered in relation to the remainder of the documents, therefore the document can be considered during this opinion. It is also noted that all the documents listed above were published before the priority date of the patent and can therefore be considered with regard to inventive step. The request is therefore allowable.

6. The original request questioned whether the claims of the patent were obvious in light of the teaching in a number of the documents above over what was stated to be the conventional form of end fitting in the art, as described in paragraph 0004 of the patent. A further argument was proposed in that the claims of the patent were obvious in light of DE2332594 and GB2241286 over the US6318403. In the observations in reply the requestor proposed a further argument regarding the novelty of the claims of the patent in light of some of the documents above. As novelty was not originally commented on in the request for an opinion I am not able to consider the lack of novelty argument which has been proposed.

## **The patent**

7. The patent was granted on 29.1.2006 and designates GB. It is still in force.

8. There is one independent claim and one semi-independent claim, which read:

Claim 1: Apparatus for expelling fluid to the external environment from a boiler (10) situated internally of a building, the apparatus comprising a conduit (16) connectable at its first end to a pressure relief valve on said boiler (10) and having its second end open, in use, to the external environment, the conduit (16) having an end portion (20) connected to its second open end, said end portion (20) being adapted to intercept fluid expelled from the second open end of the conduit (16), characterized in that the end portion (20) is substantially cup-shaped and has its concave inner surface facing the

open end of the conduit (16).

9. Claim 21 is also of particular interest and that reads:

Claim 21: A method of installing the apparatus according to any of claims 1 to 20, said method comprising the steps of i) forming an aperture (12) through an external wall (14) of sufficient dimensions to allow passage of the apparatus (1) therethrough; ii) inserting the apparatus (1) with the pre-attached end portion (20) into the aperture (12); iii) positioning the apparatus (1) such that the end portion (20) lies beyond the external surface of the wall (14); and (iv) connecting the first end of the conduit (16) to the boiler (10).

10. The following drawings help to understand the patent. A boiler is illustrated at 10 and in the event of the pressure of the water in the boiler exceeding a safe threshold, a safety valve opens to allow fluid from the boiler 10 to travel through conduit 16 and to be directed back towards the wall 14 by the cup-shaped end portion 20.

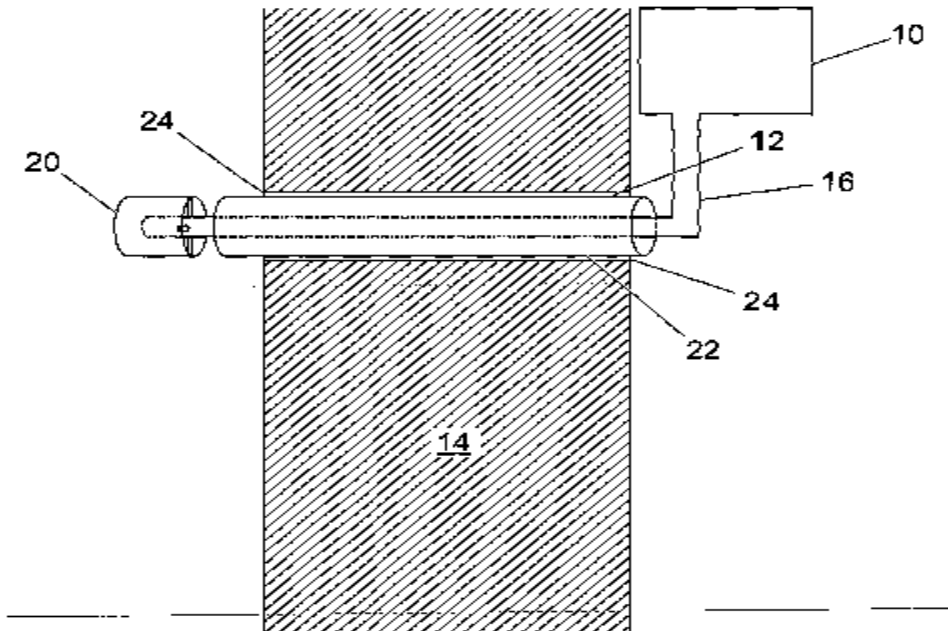

*Fig. 3*

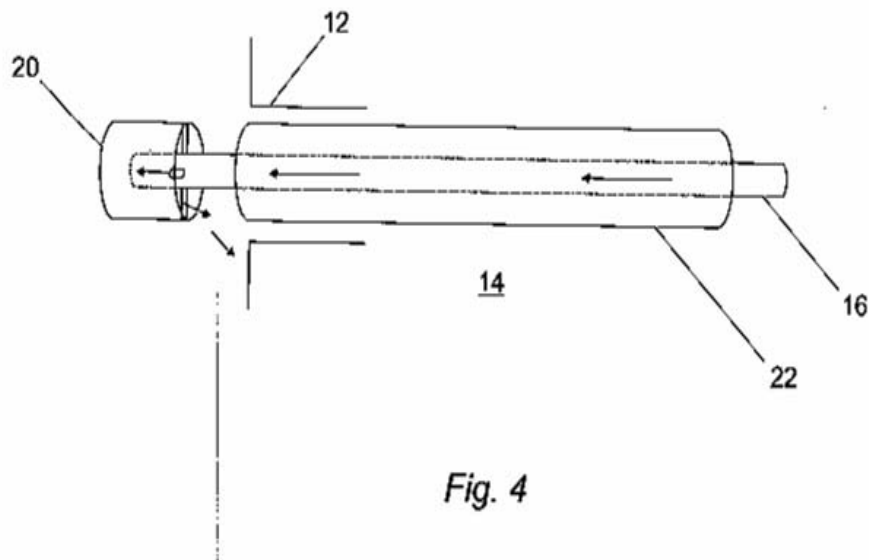

Fig. 4

### Claim construction

11. Claim construction was considered in the earlier opinion and I will therefore follow the claim construction adopted in that opinion. There has been no discussion of claim construction by either the requestor or observer in this request but of potential relevance is what constitutes a “cup-shape”. In the previous opinion it was considered that “cup-shape” should not be interpreted literally but would encompass a range of shapes which would direct fluid back in the direction from which it has come.

### Inventive step

12. Section 3 of the Act states:

An invention shall be taken to involve an inventive step if it is not obvious to a person skilled in the art, having regard to any matter which forms part of the state of the art by virtue only of section 2(2) above (and disregarding 2(3) above).

13. Two slightly different arguments have been proposed which question the inventiveness of the claims and I shall deal with them separately but using the same approach for each.

14. In order to assess the inventiveness of the claims I shall follow the test set out in *Pozzoli SPA v BDMO SA [2007] EWCA Civ 588*, the restated version of the well known approach set out in *Windsurfing International Inc v Tabur Marine (Great Britain) Ltd [1985] RPC 59*. I will therefore consider the following steps.

- (1)(a) Identify the notional “person skilled in the art”;
- (1)(b) Identify the relevant common general knowledge of that person;
- (2) Identify the inventive concept of the claim in question or if that cannot readily be done, construe it;
- (3) Identify what, if any, differences exist between the matter cited as forming part of the “state of the art” and the inventive concept of the claim or the claim as construed;
- (4) Viewed without any knowledge of the alleged invention as claimed do those differences constitute steps which would have been obvious to the person skilled in the art or do they require any degree of invention.

15. The observer has argued that the skilled person is someone who is “a manufacturer and/or installer of combination household boilers”. I agree the skilled person would have this knowledge but I think their knowledge would also extend to plumbing and plumbing products in general. Specifically, in relation to the first lack of inventive step argument made by the requestor, it seems to have been agreed by both parties, that the skilled person’s general knowledge includes the arrangement discussed in paragraph 0004 of the patent, quoted below with reference to fig 1 of the patent, which is also shown.

“Conventionally, as shown in Fig. 1, water is expelled from a boiler 10 via a aperture 12 through an external wall 14 of a building, the aperture 12 being of substantially identical diameter to the outside diameter of an outlet pipe 16. Generally, the aperture 12 and pipe 16 are approximately 15mm in diameter. The outlet pipe 16 is passed through the aperture 12 and the internal end of the pipe 16 is connected to the pressure relief valve of the boiler 10. A standard double-ended elbow fitting 18 (normally formed of two Yorkshire bends and a small length of pipe which are fitted/welded or soldered together) are then attached to the external end of the outlet pipe 16, thus directing any expelled water back against the wall 14. The water cools as it runs safely down the wall 14.”

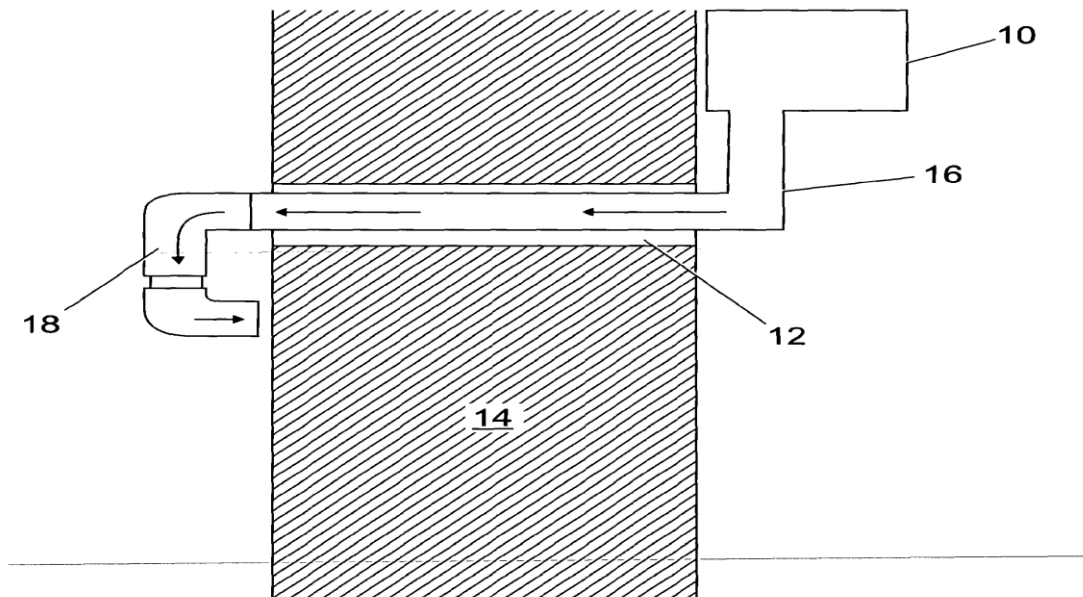

16. The inventive concept of claim 1 would appear to be the connection of a substantially cup-shaped end portion to a conduit that is connectable to a pressure relief valve on a boiler, the cup-shaped end portion having a concave surface to intercept any water exiting from the conduit.

17. The difference between the “state of the art” and the inventive concept would appear to be the use of the cup-shaped end portion instead of the U-bend shaped portion as shown above.

18. The question which therefore needs to be answered is whether the difference identified above is inventive. To aid in answering this question requestor has supplied the following patent documents:

GB1075334

This document describes a ventilator for roofs, walls and the like which consists of a cup-shaped cowl which fits over a ventilation pipe and which has a concave internal surface. The arrangement is said to allow the height that the cowl is fitted to the ventilation pipe to be varied according to weather and airflow conditions.

GB1238564

This document also shows a cup-shaped vent cap or top which can be fitted over chimney flues or gas vent pipes for intercepting gas. The vent cap has an internal concave surface. The vent cap is said to prevent the influx of rain and foreign objects and allows for efficient gas flow through the vent pipe in all external wind conditions.

DE2332594

This document also shows a roof ventilator that includes a cup-shaped cap which can be fitted to a ventilation pipe. The ventilation pipe includes a non-return valve that opens when excess air pressure is generated below a roofing skin.

EP0290390

This document shows a chimney pot that includes a cowl that can be placed on a chimney flue and although being angular in construction does appear to intercept and deflect gases from the flue. The cowl is said to be of use in covering multiple chimney pots and prevents smoke from flowing back into any of the chimney pots.

GB328713

This document shows a ventilator for vehicles, specifically for railway carriages which includes a curved upper surface, having an internal concave surface. The shape of the hood on the ventilator is said to improve the ventilator's ability to remove air from the interior of the vehicle.

GB2378750

This document shows a cup-shaped roof ventilation cowl having an internal concave surface for intercepting and deflecting air exiting from a building. The cowl is said to confer weather protection and provide for lateral air flow from the aperture in the roof of the building.

GB2332504

This document shows a chimney flue ventilation cap that is said to prevent snow and leaves etc from entering a flue of a disused chimney but allows for ventilation.

GB2241286

This document discloses an apparatus for silencing a boiler exhaust. It mentions a cowl can be placed over the silencer.

19. The requestor's argument is essentially that any of the cup-shaped cowls described in the first seven documents above could be substituted for the U-shaped portion referred to earlier. It seems to me that the person skilled in the art, particular if that person was a boiler fitter / plumber would be familiar with chimney flues and could therefore have knowledge of the types of caps/cowls discussed above. I do not however think it would be obvious for the skilled person to replace the U-shaped portion described earlier with the caps/cowls discussed above for a number of reasons.

20. Firstly, the caps and cowls of the listed documents are concerned either with preventing objects falling into the chimney flues or to modify airflow around the flue exit to manage the suction of air through the flues. The only document which seems to be directly concerned with deflecting the gas exiting the flu is EP0290390 but this is concerned with making sure smoke does not re-enter any of the other flues the cap covers. It is also of note that in this document the gas is also shown to exit the flue in an upward direction and

would therefore not direct all the gas back in the direction it has come. Secondly, the first seven documents above are concerned with gases and not high pressure liquids. Thirdly there is the question of scale as the caps/cowls of the documents seem to be conventionally much larger than the end pieces of pressure relief boiler pipes.

21. Forming claim 1 is therefore not simply a matter of replacing the U-shaped end piece with one of the cowls in the above documents. The skilled person would first have to decide to improve on the U-shaped end piece, an end piece which appears to function perfectly well. The skilled person would then have to decide that it would be worth trying a form of end piece which was similar to a chimney flue cowl, despite the fact that high pressure liquids were involved, as opposed to gases and that the chimney cowls are largely concerned with preventing foreign objects falling into the flues. The skilled person would then have to re-engineer the chimney flue cowls to reduce them in size and to allow them to cope with high pressure liquids. All this seems to me to involve ingenuity and invention.

22. I am therefore of the opinion that claim 1 is inventive in light of the first seven document above.

23. Claim 21 is directed to a method of installing the apparatus of claim 1, and is consequently inventive. Given that I am of the opinion that claims 1 and 21 are inventive, it follows that the remainder of the claims, that are appendant to claims 1 and 21, are also inventive.

24. A further objection to the claims lacking inventive step has been made by the requestor using documents US6318403, DE3439729 and GB2241286. The argument is essentially that US6318403 shows a pressure relief pipe extending from a boiler through a wall and exiting outside a building. The requestor has argued that GB2241286, which shows a silencing arrangement for an exhaust on a boiler, which does seem to exit through a wall to the outside states that "If required, a mounting flange may be provided around the inlet aperture 11 and a protective cowl may be provided over the outlet aperture 17". The requestor further argues that given this teaching an obvious form of cowl to use would be that disclosed in DE3439729.

25. The assessment of inventive step using US6318403 is essentially the same as the approach as I have discussed above. Document GB2241286 does indeed teach that it may be advantageous to fit a cowl over a pipe which exits a wall to the outside of a building. There is however no disclosure of what form that cowl could take. The question comes down once again to whether it would be obvious to the person skilled in the art to apply the type of cowl disclosed in DE3439729. For the same reasons discussed above I do not think it would be obvious to the person skilled in the art to turn to the type

of cowl disclosed in DE3439729. I therefore cannot agree the claims lack an inventive step in light of these three documents.

**Opinion**

26. In conclusion I find the claims of the patent to be inventive over the documents I have been provided with.

Lyndon Ellis

Examiner