

OPINION UNDER SECTION 74A

Patent	GB 2360542
Proprietor(s)	Mr Adam Hudson Campbell
Exclusive Licensee	
Requester	Mr Adam Hudson Campbell, on 12 July 2007
Observer(s)	Cape Industrial Services Limited NSG UK Limited
Date Opinion issued	12 October 2007

The Request

1. This opinion relates to a request as to whether patent number GB 2360542 is infringed by a scaffolding safety device, supplied by NSG UK Limited and which has been purchased and used by Cape Industrial Services.
2. The request is accompanied by a statement by the proprietor, Mr Adam Campbell. Mr Campbell also encloses a sample of the patented product (henceforth referred to as the ‘Campbell Clamp’) and a sample of the alleged infringing product (henceforth referred to as the ‘Plettac Clamp’).
3. Also accompanying the request are the following documents:
 - A photocopy of an agreement dated 23 February 2000 sent to a P Tomlinson, for Cape Industrial Services to use an unspecified fitting to facilitate the hooking on of a lanyard for a trial.
 - A photocopy of the minutes of meeting of the ‘Easter (*sic*) and Central Division’ of an unspecified company dated 21 February 2000.
 - Photocopies of pages 51-67 of a document from Cape Industrial Services relating to ‘Twin Tailed Lanyards’(undated).

Observations

4. Observations on the request were received from Cape Industrial Services in a letter dated 29 August 2007. The observations were accompanied by:

- A letter from Erhard Blobel of ALTRAD Plettac Assco GmbH, dated 27 August 2007, declaring that the Plettac Clamp has been available since 1996.
 - A photograph of the Plettac Clamp (undated)
 - A photocopy of a page from a Plettac document dated September 1996.
 - A photocopy of a list of scaffolding products for sale which may or may not be from the preceding document (undated)
 - A colour photocopy of page 12 of another list of scaffolding products for sale (undated)
 - A colour photocopy of page 12 of a third list of scaffolding products for sale (undated)
5. Observations were also received from NSG UK Limited in a letter dated 23 July 2007. These observations were accompanied by:
- A photocopy of a letter from the managing director of NSG UK Limited to Mr Campbell dated 23 July 2007.
 - A photocopy of the front cover and two pages of a Plettac Assco catalogue (undated)

Observations in reply

6. Observations in reply were received from Mr Campbell in a letter dated 16 September 2007. These were accompanied by:
- Printouts of e-mails between Erhard Blobel and Bernd Kessner of Plettac, Ken Warr and Adam Campbell (dated 1-2 August 2007)
 - An e-mail from Aimee Reid of ThyssenKrupp Safeway Inc to Adam Campbell (dated 25 January 2007)
 - A photocopy of a Plettac Assco brochure (dated May 2001)

The Patent

7. The patent was granted on 24 April 2002 and is still in force. The application was filed on 29 November 2000, but with a priority date of 17 December 1999. The application was first published as WO 01/44599 on 21 June 2001 and then as GB 2360542 on 26 September 2001.

8. The patent relates to a scaffolding device which has a clamping portion and an attachment portion. The preferred embodiment is illustrated in figures 2 and 3:

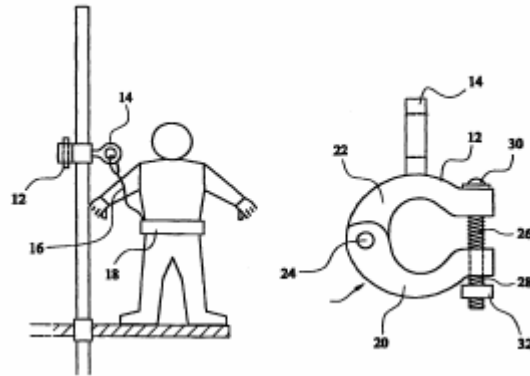

9. The clamping portion 12 can be removably secured to a scaffolding pole and an attachment portion 14 which can receive a tether 16 for tethering a worker to the safety device. The two portions are rigidly linked together
10. The patent has 14 claims, of which claim 1 is the only independent claim. The request does not specify which claims are allegedly infringed, so I will assume that the request pertains to all claims.
11. Claim 1 reads as follows:

A scaffolding safety device comprises a clamping portion and an attachment portion, wherein the clamping portion is operable to be removably secured to a scaffolding pole and the attachment portion is operable to receive a tether for tethering a worker to the scaffolding safety device, and in which the clamping portion and the attachment portion are rigidly linked together.

The Plettac Clamp

12. A sample of the Plettac Clamp has been provided by the requester. It appears to be identical to the Plettac Clamp shown in a photograph provided by Cape Industrial Services. Therefore, the sample clamp will be used as the main reference as to the technical features of the Plettac Clamp.
13. In their observations, Cape Industrial Services state that the Plettac Clamp (referred to in the observations as 'Eyebolt Coupler') is 'virtually identical' to Mr Campbell's 'Jordan Clamp'. They also state that they have purchased and used only a relatively small number of the Plettac Clamps, which they purchased from NSG UK Limited.

Discussion

14. The request seeks only an opinion on infringement hence my task is to determine whether the Plettac Clamp infringes the patent. My task is not to determine whether the Plettac Clamp, or a variation of it, pre-dated the patent, thereby calling the validity of the patent into question. If any of the parties wishes to question the validity of the patent then they are at liberty to request an opinion in that respect. To show that the patent is invalid, compelling evidence must be provided.
15. My first task in considering infringement is to decide how to construe claim 1. Then I must decide whether the Plettac Clamp falls within the scope of the claim so construed. The latest guidance on how to construe claims is given by Lord Hoffman in *Kirin-Amgen Inc v Hoescht Marion Roussel Limited* [2005] RPC 9. In this case he summarizes the approach to claim construction by saying “*The question is always what the person skilled in the art would have understood the patentee to be using the language of the claim to mean*”.
16. In this particular case I believe that the scope of the claim is generally clear from the wording used. I would note that none of the parties involved has put forward any suggestions as to how it should be construed.
17. I will therefore take the wording of the claim at face value and move on to consider whether the Plettac Clamp falls within the scope of the claim.
18. The claim is directed to ‘*a scaffolding safety device*’. From the attachments submitted with observations it would seem that the Plettac clamp was designed primarily to allow loads to be suspended from scaffolding. However Cape Industrial Services also confirm that it was advised by NSG that the clamp would be suitable for attaching scaffolder’s landyards during scaffolding operations. This is confirmed in a copy of an e-mail exchange at the beginning of August 2007 between Ken Warr and Plettac’s Bernd Kassner and A.E. Blodel, I am satisfied that the Plettac clamp can be considered as a scaffolding safety device.
19. The next feature of the claim is ‘*a clamping portion [which] is operable to be removably secured to a scaffolding pole*’. The detailed description says that this preferably comprises two pivoted jaws. I am satisfied having examined the sample that the Plettac Clamp clearly has the same arrangement.
20. The claim then states that the device has an ‘*an attachment portion [which] is operable to receive a tether for tethering a worker to the scaffolding safety device*’. Both clamps have solid ring structures that serve as attachment portions. The ‘Twin Tailed Lanyards’ presentation from Cape Industrial Services shows that a worker can be tethered to such a ring structure
21. Finally the claim requires, ‘*the clamping portion and the attachment portion are rigidly linked together*’. On both of the sample clamps the two portions are

securely and permanently linked together in similar ways.

22. Therefore, I believe that the Plettac Clamp has all the features required by claim 1. I should note that neither of the alleged infringers has really suggested otherwise. It follows therefore that the production, sale, distribution or use of such a clamp in the UK, even if only in relative small numbers, infringes the patent.

Opinion

23. I conclude that the Plettac Clamp infringes patent number GB 2360542.

Application for review

24. Under section 74B and rule 77H, the proprietor may within three months of the date of issue of this opinion, apply to the comptroller for a review of the opinion.
25. Under rule 77H(5) such an application for review may be made by the proprietor only on the grounds that by reason of its interpretation of the specification of the patent the opinion wrongly concluded that a particular act would not constitute an infringement of the patent.

Richard Nicholls
Examiner