



## PATENTS ACT 1977

BETWEEN

Anthony Brian Mallows

Claimant

and

Abmwaterstop Ltd

Defendant

PROCEEDINGS

Reference under Section 8 of the Patents Act 1977 in respect of GB patent  
number GB2537810

HEARING OFFICER

Phil Thorpe

---

## DECISION

### Introduction

1. This decision relates to a reference under section 8(1)(a) of the Patents Act 1977 concerning entitlement to patent application GB2537810. The application, which was filed on 18<sup>th</sup> March 2015, is currently in the name of Abmwaterstop Ltd. The inventor listed on the application is Anthony Brian Mallows. The statement of inventorship filed with the application states that Abmwaterstop derived the right to the grant of the patent from its employment of the inventor.
2. The reference was initially filed by Anthony Mallows on 23<sup>rd</sup> March 2018. In his amended statement of grounds Mr Mallows seeks the following:
  - i) An order that the claimant may make an application for a patent for the whole or part of any matter comprised in UK patent application GB2537810 and that any such application shall be treated as having been filed on 18 March 2015.
  - ii) An order that the claimant be recorded as the Applicant / Proprietor owner of UK Patent Application No. GB2537810.
  - iii) Costs.
  - iv) Further or other relief.

3. A counterstatement was filed on behalf of Abmwaterstop Ltd by Nicholas Kirkham, of Graham Watt & Co LLP, on 18<sup>th</sup> May 2018.
4. The normal evidence rounds then ensued, and a hearing was initially agreed for the 7<sup>th</sup> and 8<sup>th</sup> February 2019.
5. On 17<sup>th</sup> January 2019 Julia D'Arcy of Harrison IP, acting on behalf of Mr Mallows, requested an adjournment of the hearing. The reason given was that Mr Mallows had received notification from Begbies Traynor LLP indicating that the directors of Abmwaterstop were taking steps to place the company into creditors' voluntary liquidation.
6. The office contacted Begbies Traynor on 22<sup>nd</sup> January 2019, and was advised that Abmwaterstop would go into liquidation on 31<sup>st</sup> January 2019 with the liquidator taking over on 1<sup>st</sup> February 2019. The hearing was therefore adjourned until the intentions of the liquidator were confirmed.
7. In a letter dated 21<sup>st</sup> February 2019 the Office sought confirmation of the liquidator's intentions with respect to contesting the reference to entitlement. Begbies Traynor responded on 4<sup>th</sup> March 2019 to advise that the Joint Liquidators would not be partaking in any proceedings relating to the patent application GB2537810. The withdrawal of the defendants means that the reference is being treated as uncontested.

### The Patent Application

8. Patent application GB2537810 relates to a flexible seal for providing a barrier to prevent water passing between an appliance, such as a bath or shower, and a wall. The provision of apertures and ribs extending across the seal (see figures 2 and 3 reproduced below) is said to be an improvement on the prior art.

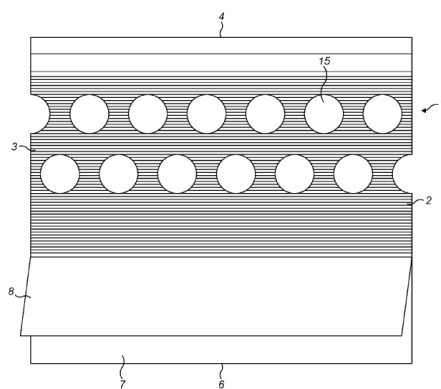

FIG. 2

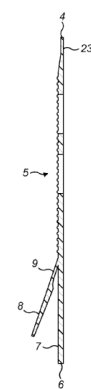

FIG. 3

### Summary of facts and submissions

9. Since the reference is being treated as uncontested, I must accept the facts of the case to be those described in the Statement of Grounds and supporting documentation submitted by the claimant unless it will be clearly wrong to do so. These facts can be summarised as follows.

10. Mr Mallows filed an earlier UK patent application GB2364555 on 7<sup>th</sup> July 2000, which was published on 20 January 2002 and which relates to a method of using a flexible seal. This was granted, but expired on 7<sup>th</sup> July 2010.
11. Mr Mallows had informal discussion with the directors of Abmwaterstop Ltd, Andrew Bartlett and Mike Stephens, about his earlier patent, which Mr Bartlett had used previously and wanted to order more of. Abmwaterstop Ltd thought that Mr Mallows earlier invention could be commercially interesting and wanted to invest in a re-launch.
12. Mr Mallows then set about making improvements to his earlier invention with no input from anyone else. Mr Mallows was not, and never had been, an employee of Abmwaterstop Ltd. Mr Mallows was not offered any money or benefits for his work, and nor was he working under any contract with Abmwaterstop Ltd.
13. Whilst evidence submitted by Mr Mallows on 6<sup>th</sup> September 2018 shows that he appeared to act on behalf of Abmwaterstop Ltd in a number of capacities, in a further response filed on 28<sup>th</sup> November 2018 Mr Mallows states that he was in the habit of undertaking email communication on behalf of Mr Stephens, but maintains that he received no remuneration from Abmwaterstop Ltd for performing these tasks.
14. Mr Mallows submits that the present patent application GB2537810 was incorrectly filed naming Abmwaterstop Ltd as the applicant, and that due to the lack of any agreement, contractual or otherwise, or any other obligation between Mr Mallows and Abmwaterstop Ltd, that Abmwaterstop Ltd has no entitlement to the UK patent application GB2537810.
15. Mr Mallows submits that he is solely entitled to the ownership of the UK patent application GB2537810 under Section 7(2) of the Patents Act, as he maintains that Mr Bartlett and Mr Stephens “did not contribute to the novelty or inventive step of the invention and may not properly be considered as inventors”.

## **Conclusions**

16. On the basis of the evidence provided by the claimant, and taking into account that the defendant is being treated as having withdrawn from proceedings, I am satisfied that Mr Mallows devised the improvements to his previous seal, resulting in the invention in GB2537810, without contribution from any other parties.
17. Further there is nothing before me to suggest that anyone else has a right to the invention.

## **Declaration & Order**

18. I hereby declare that Anthony Brian Mallows is entitled to the invention of patent application number GB2537810.

19. I therefore order that Anthony Brian Mallows be named as sole proprietor of patent application GB2537810 and that the application proceed solely in his name.

### **Costs**

20. The claimant has requested a contribution towards his costs. Notwithstanding that the defendants were deemed to have withdrawn from the proceedings the claimant is entitled to an award of his costs up to the point of that determination, in this case the 4<sup>th</sup> March 2019. I would however note that the defendants are in liquidation and this might impact on the claimant's ability to recover any costs. That said having reviewed the proceedings I believe that an on-scale award of £400 is justified to cover proceedings up until the defendant was deemed to have withdrawn on the 4<sup>th</sup> March 2019.

21. I will however allow the claimant 2 weeks from the date of this decision to make a submission on costs should he believe that an award in excess of that amount be justified. In the absence of any such submission then the above sum will become payable by the defendants within 7 days of the expiry date of the appeal period set out below.

### **Appeal**

22. Any appeal must be lodged within 28 days after the date of this decision.

**Phil Thorpe**  
**Deputy Director acting for the Comptroller**