



PATENTS ACT 1977

**FRAUNHOFER-GESELLSCHAFT ZUR
FÖRDERUNG DER ANGEWANDTEN
FORSCHUNG E.V**

Proprietor

PROCEEDINGS

Applications under section 74B for a review of Opinion 02/17 & Opinion 5/17, both in respect of EP(UK) 2086102

HEARING OFFICER

Phil Thorpe

Hearing date: 02 May 2019

DECISION

Introduction

- 1 In opinion 02/17, issued 25th April 2017, the examiner concluded that claim 1 of European Patent 2086102 B1, entitled “Inverter for converting an electric direct current into an alternating current or an alternating voltage”, lacked novelty.
- 2 The patent was then the subject of a second opinion, 15/17, which issued 21st December 2017. In this second opinion, the examiner provided his views on new and different questions to those previously considered, including one which asked whether claim 9 contains added matter. In respect of this particular question, the examiner concluded that claim 9 was invalid because it discloses added matter.
- 3 The proprietor of the patent has requested a review of each opinion under section 74B of the Patents Act (the “Act”), asking for the parts of the opinion that went against it to be set aside. Each application for review was received within the three-month period from the date of issue of the relevant opinion with both applications being accompanied by a statement setting out the proprietor's grounds for review. The requester of the original opinions has chosen not to be party to the review proceedings.
- 4 The proprietor asked to be heard on each request so came before me at a hearing held 2nd May 2019. The proprietor was represented by James Main of JA Kemp (the proprietor's UK patent attorney), Markus von Rudno (also of JA Kemp), Mr Tankred

Zimmermann (German Patent Attorney), and Dr Gisbert Hohagen (German Attorney-at-Law).

5 I regret the length of time it has taken to issue this decision.

Grounds for review

6 The grounds for a review of an Opinion are set out in rule 98(5) of the Patents Rules 2007 which reads:

98(5). The application may be made on the following grounds only -

(a) that the opinion wrongly concluded that the patent in suit was invalid, or was invalid to a limited extent; or

(b) that, by reason of its interpretation of the specification of the patent in suit, the opinion wrongly concluded that a particular act did not or would not constitute an infringement of the patent.

7 The nature of a review under section 74B was considered by the Patents Court in *DLP Limited*¹ in which Kitchen J said (my emphasis):

22. In the case of an appeal under rule 77K, the decision the subject of the appeal is itself a review of the opinion of the examiner. More specifically, it is a decision by the hearing officer as to whether or not the opinion of the examiner was wrong. I believe that a hearing officer, on review, and this court, on appeal, should be sensitive to the nature of this starting point. It was only an expression of an opinion, and one almost certainly reached on incomplete information. Upon considering any particular request, two different examiners may quite reasonably have different opinions. So also, there well may be opinions with which a hearing officer or a court would not agree but which cannot be characterised as wrong. Such opinions merely represent different views within a range within which reasonable people can differ. For these reasons I believe a hearing officer should only decide an opinion was wrong if the examiner has made an error of principle or reached a conclusion that is clearly wrong. Likewise, on appeal, this court should only reverse a decision of a hearing officer if he failed to recognise such an error or wrong conclusion in the opinion and so declined to set it aside. Of course this court must give a reasoned decision in relation to the grounds of appeal but I think it is undesirable to go further. It is not the function of this court (nor is it that of the hearing officer) to express an opinion on the question the subject of the original request.

8 Hence a review is not intended to be a second opinion on the matters presented in the opinion. Whether I necessarily agree or disagree with the examiner's opinion is also not the matter at hand in this review. Furthermore, the matter is not whether any of the parties agrees or disagrees with the opinion. What matters is whether the examiner made an error of principle or reached a conclusion in their opinion which was clearly wrong.

¹ *DLP Limited* [2007] EWHC 2669

9 Here the proprietor submits that the examiner has made a clear mistake in his assessment of novelty (opinion 02/17) and of added matter (opinion 15/17) and as a result arrived at conclusions that are clearly wrong. I shall consider each of these alleged mistakes in turn but first provide an overview of the patent at the heart of the two opinions.

The patent

10 In broad terms the patent provides a DC/AC convertor (“inverter”) which converts a direct electrical voltage (DC), especially that provided by a solar generator, into an output suitable for feeding into a grounded network. That output might be an alternating current suitable for feeding into the public grid, or an alternating voltage (AC) suitable for feeding into an independent island grid. The patent builds on known inverter configurations by incorporating additional connection paths between a pair of connection lines that electrically connect a bridge circuit with a pair of choked AC terminals that feed into a grounded network. Figure 1 of the patent, reproduced below, shows one form of the modified inverter:

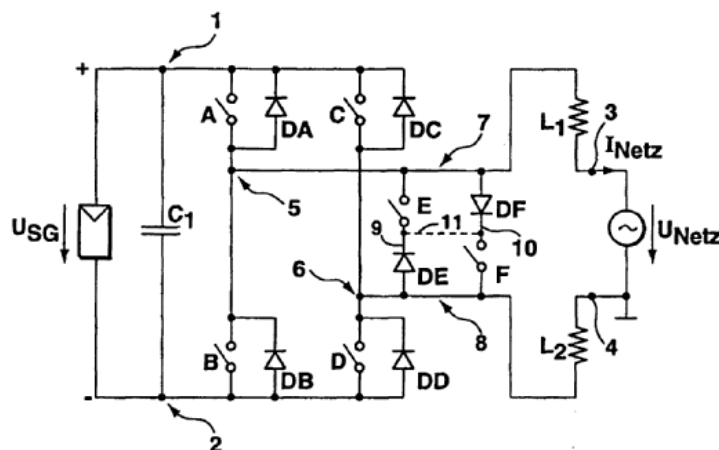

Fig. 1

- 11 In Figure 1 the additional connection paths include switches E and F, and diodes DE and DF located between connection lines 7,8. The connections lines 7,8 are shown connected to the bridge circuit at nodes 5,6 respectively, and terminating at alternating voltage terminals 3,4, via chokes L₁, L₂.
- 12 During the positive half wave of the public electrical grid, switches A, D of the bridge circuit are synchronously closed and opened whilst switch E is closed for at least a portion of the positive half wave. Conversely, during the negative half wave of the public grid, switches B, C are synchronously closed/opened whilst switch F is closed for at least a portion of the wave.
- 13 The additional connection paths serve to provide an additional path for the choke current, one that during ‘free wheeling’ phases of inverter’s operation serve to ohmically decouple the generator side of the inverter from the grid side. This decoupling avoids voltage jumps and unwanted current flows associated with prior symmetrically and non-symmetrically run inverters. As explained at the hearing, the invention combines the advantages of existing inverters operated with symmetric or

non-symmetric clocking but without the inherent disadvantages associated with each.

- 14 Figures 5(a-d) of the patent provide a series of what are known as “equivalent circuit diagrams” which show how in practice the additional connection paths of the invention serve to alternately couple/decouple the DC and AC sides of the inverter during a network feeding operation. Figure 7 shows the switched states of bridge switches AD;BC and the additional switches E,F relative to the grid voltage during a grid feeding operation.

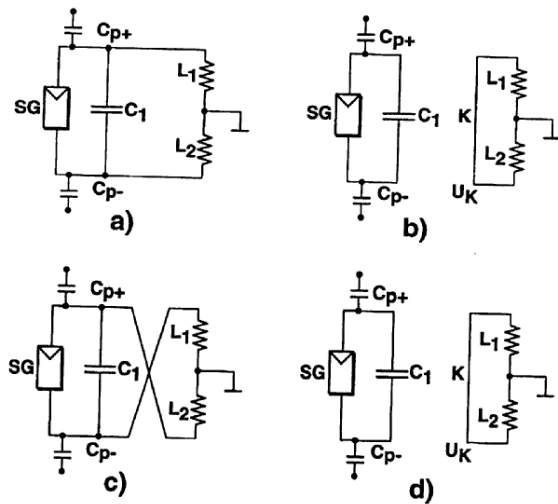

Fig. 5

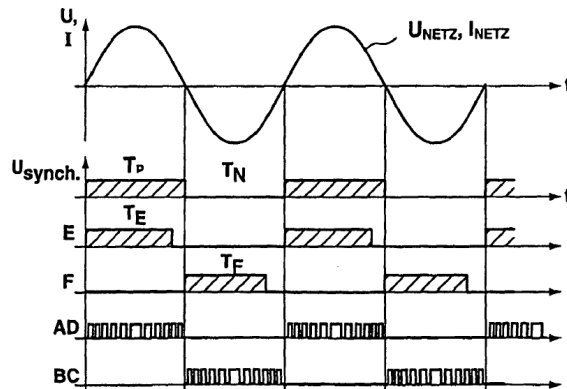

Fig. 7

- 15 Claim 1 of the patent reads:

1. An inverter for feeding the energy originating from a solar generator to a grounded network, the inverter comprising:

two solar generator terminals (1, 2);

an energy buffer (C1) for buffering the energy originating from the solar generator;

a bridge circuit which is connected in parallel to the energy buffer (C1) and comprises at least two parallel branches which each comprise two switch units (A, B; C, D) connected in series, in parallel to each of which a rectifier diode (DA, DB, DC, DD) is connected; and

at least two alternating voltage terminals (3, 4) each of which is individually connected, via a connection line (7,8) in which one respective choke inductivity (L_1, L_2) is provided, to one of the parallel branches of the bridge circuit between two switch units (A, B; C, D) via a connection node (5, 6),

characterized in that

between the at least two connection lines (7, 8), a circuit arrangement (E, DE, F, DF, 9, 10, 11) is provided which may be controlled such that the circuit arrangement electrically connects the at least two connection lines 7, 8) in a

first state and electrically separates the at least two connection lines (7, 8) in a second state.

16 A method of use is provided in claim 9:

9. A method for feeding the energy originating from a solar generator to a grounded network, the method comprising the steps of:

during at least a section of a half-wave of the alternating voltage of the network, connecting and separating a first terminal of an energy buffer (C1) to a first choke inductivity (L1) and a second terminal of the energy buffer (C1) to a second choke inductivity (L2) in a clocked manner;

during at least a section of a next half-wave of the alternating voltage of the network, connecting and separating the first terminal of the energy buffer (C1) to the second choke inductivity (L2) and the second terminal of the energy buffer (C1) to the first choke inductivity (L1) in a clocked manner;

characterized by:

separating the terminals of the energy buffer (C1) from the first choke inductivity (L1) and from the second choke inductivity (L2) when the first choke inductivity (L1) and the second choke inductivity (L2) are electrically connected to each other on their respective sides facing away from the network.

Opinion 02/17 and the novelty of claim 1

17 In opinion 02/17, the examiner was asked to consider the validity of the claimed invention over the disclosures of two prior art documents, one of which being a Japanese patent application, JPH 09-140157 ("MAKINO"). The opinion focused principally on figure 1 of MAKINO reproduced below.

[FIG.1]

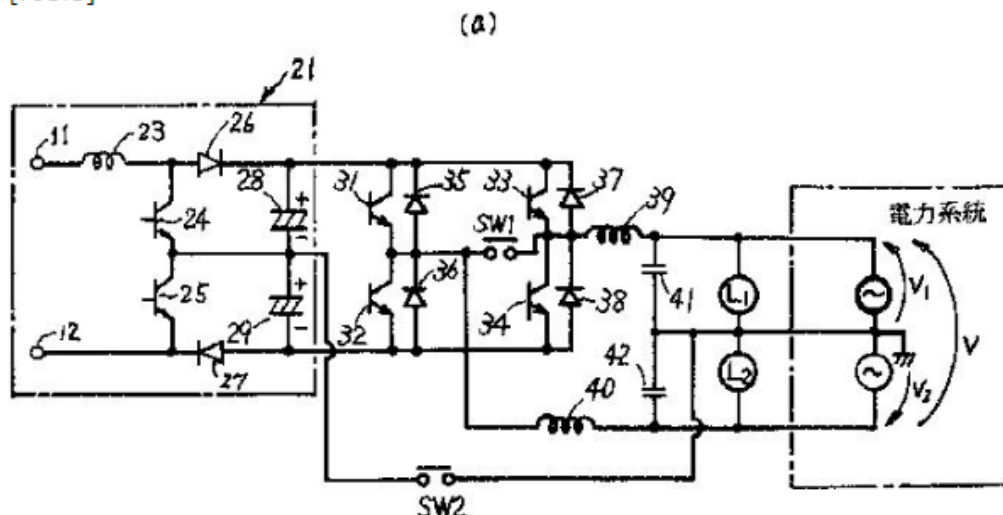

- 18 The opinion went on to conclude that claim 1 of the patent lacked novelty over MAKINO. The conclusion he reached in respect of the other prior document is of no concern here.
- 19 The proprietor submits that the examiner's opinion in respect of MAKINO is clearly wrong and is so because of incorrect assumptions made by the examiner when reviewing the proprietor's observations filed in respect of the opinion request. Had the examiner not made those incorrect assumptions, and had instead considered the claim as a whole, then the examiner would have recognised that claim 1 of the patent was clearly novel over MAKINO.
- 20 The incorrect assumptions the proprietor point to boil down to two key points: i) the examiner's approach to interpreting claim 1 and whether the applied interpretation was too broad; and ii) the examiner's understanding of what is taught by MAKINO. This second point goes particularly to a submission made at the hearing that even on a literal reading of claim 1, MAKINO did not provide a novelty destroying disclosure.
- 21 To evidence the incorrect assumption made by the examiner in respect of the interpretation given to claim 1, the proprietor draws my attention to paragraphs 50 to 53 of the opinion. In paragraph 50, the examiner sets out what he believes to be the common ground between the parties regarding the anticipation of the preamble of claim 1 by MAKINO. Paragraph 50 is reproduced here with the proprietor's emphasis:

50. *From their various submissions regarding MAKINO, I believe it is common ground between the parties that MAKINO discloses the preamble (i.e. the pre-characterising portion) of claim 1. It is therefore only necessary for me to consider whether MAKINO discloses the characterising part of claim 1. Following the numbering given in the request, the features of the characterising part of claim 1 are:*

1.4.1.2 between the at least two connection lines a circuit arrangement is provided,

1.5 the circuit arrangement may be controlled

1.5.1 such that the circuit arrangement electrically connects the at least two connection lines in a first state, and

1.5.2 electrically separates the at least two connection lines in a second state.

- 22 In paragraph 51, the examiner reviews the requester's analysis of the claimed features set out in paragraph 50 before moving on to the observer's submissions in paragraphs 52 and 53, reproduced here with my emphasis:

52. *The observer argues that MAKINO does not disclose the characterising part of claim 1. Their argument is subtle, and it rests on interpreting features 1.4.1.2 – 1.5.2 in light of feature 1 (set out at paragraph 28 above). The observer argues that MAKINO only functions as an inverter for feeding energy from a solar generator into a grounded network (as required by feature 1) if switches SW1 and SW2 are in the open state, i.e. when the inverter of MAKINO is in its "connected mode". In contrast, when switches SW1 and SW2 are closed (i.e. when the inverter of MAKINO is in the "stand alone mode") the observer says that no feeding of energy into the network occurs. Thus, in the stand alone mode, the observer says the inverter of MAKINO is not suitable for feeding energy from a solar generator into a grounded network (since no feeding of energy to the network occurs in this mode). In other words, the observer is arguing that I should only consider the inverter of MAKINO as being an*

inverter suitable for feeding energy from a solar generator into a grounded network when it is functioning in the “connected mode” (i.e. when switch SW1 is closed). The observer says that when MAKINO occupies the “connected mode” it cannot be further controlled in a way that would produce the first and second states defined by features 1.5.1 and 1.5.2.

53. The requester responds by saying that claim 1 should be evaluated based on the actual features of the claim. They say that, because the observer has admitted that the preamble of the claim – and therefore feature 1 – is disclosed by MAKINO, it is not open to the observer to argue that the combination of feature 1 with features 1.5.1 and 1.5.2 is not disclosed by MAKINO. The requester says that features 1.5.1 and 1.5.2 simply define that the circuit arrangement can be controlled to provide the two states, i.e. the electrical connection of the connection lines in the first state and the electrical separation of the connection lines in the second state. They say that the nature of the two states defined by claim 1 is simply not specified any further by claim 1. I agree with the requester. Claim 1 must stand or fall based on the technical features defined by the claim. Having accepted that feature 1 is disclosed by MAKINO on one hand, I do not believe it is open to the observer to argue that it is not disclosed on the other. I therefore agree with the requester that switch SW1 corresponds to the “circuit arrangement” of feature 1.4.1.2 and that MAKINO discloses the switch SW1 is controllable to provide the first and second states required by features 1.5, 1.5.1 and 1.5.2. Thus, in my opinion, claim 1 lacks novelty over MAKINO.

- 23 The proprietor refers to the relevant passages in page 17 of their observations where, following a review of the constructional details of the inverter of MAKINO, it was acknowledged that “...the subject matter of Makino substantially corresponds to the preamble of claim 1 of the 102 patent”.
- 24 The observations go on to explain the different modes of operation of the inverter in MAKINO, highlighting that the inverter only feeds energy originating from solar generator into a grounded network when and only when it is in a ‘connected’ mode with switches SW1 and SW2 open. In this mode of operation, MAKINO does not, in the proprietor’s opinion, use a circuit arrangement that is controllable in the manner required of claim 1. The switches simply serve to change the mode of operation from the connected (network feeding) mode to a standalone mode where there is no feed to the network.
- 25 With this in mind, the observations stated that “[w]ith regard to the question as to whether the characterizing part of the 102 patent is disclosed by Makino or not, the purpose defined in the preamble is essential and must be considered; namely, that the inverter is feeding energy originating from a solar generator into a grounded network”.
- 26 The observations are thus asking the examiner to infer purpose and function to the final part of the claim: that while the inverter is feeding energy into the network (the operation being derived from the opening two lines of the claim), the connection lines 7,8 are connected or separated from one another by appropriately controlling the circuit arrangement of the characterising part of the claim. It was the examiner’s subsequent failure to do this – as evidenced by his comments in paragraph 53 – which resulted in the opinion wrongly concluding that the invention lacked novelty over MAKINO.
- 27 The proprietor presents a convincing case to demonstrate how the described invention might be said to differ from the invention disclosed in MAKINO. However, the question for me here is not whether the described invention operates differently

from that disclosed in MAKINO, but rather whether the examiner had been clearly wrong to say that MAKINO fell within the scope of claim 1 as currently worded.

- 28 If the examiner, in reaching his conclusion, had failed to consider the issue of construction or ignored the observations on that from the requestor or the proprietor, I would have no hesitation in saying that he made an error in principle, one that may or may not have resulted in a conclusion that is clearly wrong. However, having considered the proprietor's arguments and having reviewed the Opinion 02/17, I do not believe that is the case. Not only did the examiner set aside part of the opinion to consider some general points of construction (paragraphs 14 to 19), he then went on to consider the very specific points raised in the observations and the requestor's subsequent response regarding MAKINO and how the final characterising part of claim 1 should be construed. It is clear to me that the examiner had a clear appreciation of the point being made by the proprietor in its observations but, after considering also the requestor's arguments, reached a conclusion that an apparatus claim directed as being suitable for a particular purpose, needed to be construed as such. I do not think he erred in principle or reached a conclusion on construction that was clearly wrong.
- 29 That the examiner chose a broader construction to that advocated by the proprietor was not in my view unreasonable especially given how the proprietor has chosen to word claim 1. The proprietor could have for example explicitly set out in more detail in the claim what the precise purpose of the circuit arrangement was, but it chose not to do so. It relies instead on this being implicit from the wording of other parts of the claim. The proprietor's construction may well be within what Kitchen J, as he was then, described as the "range within which reasonable people can differ" but so too in my view is the construction adopted by the examiner.
- 30 Having considered the examiner's approach to construction, there remains the question of whether the examiner was clearly wrong to conclude that MAKINO anticipated the invention of claim 1. In short, I do not believe the examiner's opinion on this point to be clearly wrong. The examiner has clearly considered the disclosure of MAKINO and concluded that it does disclose a circuit arrangement that can disconnect a grid side of the inverter from a generator side. Having also reached a view on how the claim should be construed, I can see nothing clearly wrong in the examiner's conclusion that MAKINO anticipates the claim.

Opinion 15/17 and added matter

- 31 In opinion 15/17 the examiner was asked to consider, amongst other things, whether method claim 9 extends the disclosure of the parent application from which the patent was derived and is thus invalid. The examiner concluded, at paragraph 56, that claim 9 of the patent *does* extend the disclosure of the parent application and as a consequence claim 9 is invalid for added matter. This is a conclusion the proprietor considers to be wrong and wishes me to set aside.
- 32 In reaching his opinion on added matter the examiner adopted the *Bonzel*² test for assessing added matter, a test which involves the steps of: (1) ascertaining through the eyes of the skilled addressee what is disclosed, both explicitly and implicitly in

² *Bonzel v Intervention* (No 3) [1991] RPC 553

the application; (2) doing the same in respect of the patent; and then (3) comparing the two disclosures and deciding whether any subject matter relevant to the invention has been added whether by deletion or addition. The comparison is strict in the sense that subject matter will be added unless such matter is clearly and unambiguously disclosed in the application either explicitly or implicitly.

- 33 To assist with the third step, the examiner drew on the *Houdaille*³ test to help him determine whether certain features not appearing in claim 9 constitute added matter. In short, the *Houdaille* test says that the skilled person must be able to recognise directly and unambiguously that: (1) the omitted feature is not explained as essential in the original disclosure; (2) it is not, as such, indispensable for the function of the invention in light of the technical problem it serves to solve, and (3) the replacement or removal requires no real modification of other features to compensate for the change.
- 34 The proprietor does not challenge the examiner's decision to adopt *Bonzel* but does raise questions about his application of the test. The proprietor also raises questions about the relevance and application of the *Houdaille* test.
- 35 More specifically the proprietor submits that the examiner failed to properly apply the *Bonzel* test through the eyes of the skilled person, particularly in respect of the first step of ascertaining what is disclosed, both explicitly and implicitly in the parent application. It notes:

"There is no discussion in the "Added Matter" section... of how specifically "an electrical engineer with knowledge of inverters for converting direct current voltages to alternating current voltages" (who is identified as the skilled person in relation to the Inventive Step discussions....), would have understood the disclosure of the parent application. In fact, in relation to added matter, the Examiner only generally refers to the "skilled person", but makes no attempt to consider what an electrical engineer might learn from the disclosure of the parent application. This is not appropriate, and is a clear divergence from established case law."

- 36 Had the examiner considered the disclosure through the eyes of an electrical engineer then, the proprietor argues, he would have concluded that the subject matter of claim 9 is directly and unambiguously derivable from the parent application as filed.
- 37 At the hearing the proprietor accepted that the examiner had identified the skilled person in paragraphs 12 to 14, and no challenge was made as to who that person would be. The proprietor also confirmed that the examiner's construction of claim 9 is not being challenged. The real question here is therefore not whether the examiner failed to adopt the mantle of the skilled person, but rather whether he fully appreciated what the skilled person would understand of the disclosures of the parent application and the patent.

³ The "Houdaille Test" set out in EPO Board of Appeal in T331/87, summarised by Kitchen LJ in *Nokia Corporation v IPCOM GMBH & Co KG (No. 3)* [2013] RPC 5.

- 38 Expanding on its argument, the proprietor recognises that there will be features which are essential to the invention and others that are not. Figures 1 and 2 show inverter topologies: Figure 2 showing a conventional topology and Figure 1 showing the 'inventive' topology (which is based on the topology shown in Figure 2). For each of these circuits there is a corresponding functional "equivalent circuit diagram": Figures 3 and 4 being provided for the conventional inverter, and Figure 5 for the inventive inverter. The proprietor submits that it is from a comparison of these equivalent figures that the skilled person would, as an electrical engineer, understand the overall operation of the inventive inverter, and that the 'how', i.e. the specific choice of circuit structure, would not be important.
- 39 In the proprietor's opinion, the examiner overlooked the relevance of the equivalent circuit diagrams when assessing the disclosures of the parent application and the patent, and was therefore clearly wrong to conclude (a) that the disclosure of the parent application was linked to the use of a specific bridge circuit, namely that shown in Figure 1, and (b) that claim 9 relates to a "general method" of feeding energy into a grounded network, and omits essential features of the invention.
- 40 The proprietor submits that the skilled person would immediately recognise the importance of the equivalent circuit diagrams for describing functionality of a circuit and consider them a meaningful disclosure that is not inextricably linked to one particular embodiment of the circuit diagram. With the general teaching of the parent application in mind, the proprietor submits the skilled person would recognise that there are many different circuit topologies, i.e. different bridge circuits, that might be used to achieve the different states illustrated in Figure 5, and that independent of the bridge circuit used, no changes would be required of the basic inventive structure (the means for separating the AC and DC sides). Furthermore, the skilled person would conclude that nothing essential to the invention has been omitted from claim 9: all of the essential features of the invention are present in the claim.
- 41 If the examiner had indeed arrived at something other than a full and accurate understanding of what is taught by the parent application or the patent, it follows that the comparison made at step 3 of *Bonzel* may be wrong. Having asserted that the examiner's understanding of the disclosure was flawed, the proprietor presented me with an argument that the examiner was wrong to make use of the *Houdaille* test for omitted features because this was not a case of starting from a narrow claim from which a feature has been omitted. Rather the claim as it is, reflects what is shown in Figure 5, something the skilled person would appreciate.
- 42 This is a different and parallel argument to that put forward in the proprietor's written submissions in which it is argued that the examiner would have answered each step of the *Houdaille* test positively had he properly ascertained what the skilled person would have understood of the disclosure.
- 43 At the hearing I was provided with a very thorough walk through of the disclosure of the patent of claim 9, for which I am very grateful. I must confess that with this further insight provided at the hearing I find the arguments submitted by the proprietor quite persuasive. But, as with the question of novelty, the question I must decide upon is whether the examiner made an error in principle or reached a conclusion that is clearly wrong.

- 44 Having carefully considered the matter, I do not believe the examiner was wrong to apply either the *Bonzel* test or the *Houdaille* test in his assessment of added matter: *Bonzel* is the recognised starting place for the assessment of added matter, and I believe it quite appropriate for the examiner to apply *Houdaille* given the possibility of added matter by deletion. Furthermore, having reviewed the opinion, I am happy that the examiner's application of each test was right – the examiner did consider the relevant disclosures through the eyes of a skilled person, and the identity of that skilled person was appropriate.
- 45 The review of Opinion 15/17 therefore really seems to boil down to whether the examiner's assessment of what the skilled person would understand of the parent application and claim 9 of the patent is clearly wrong? I do not believe it is. From the discussion in paragraphs 49 to 51 of the opinion, in particular paragraph 50 and the opening of 51 reproduced below, it is clear that the examiner was very much alert to the role of the equivalent circuit diagrams and how they might be utilised by the skilled person in understanding the disclosures, particularly in terms of what features would be essential and non-essential to the invention.

50. I do not accept the observer's argument that the skilled person would understand that the essential aspect of the invention is explained by the equivalent circuit diagrams of Fig. 5 without any reference to the design of the inverter. On the contrary, I believe that the skilled person would understand that the description in respect of Figs. 5 and 7, upon which the observer relies, refers to the description of the inverter of Fig. 1. Firstly, I note that when Fig. 5 is described on page 16, lines 6- 7, it is stated that, "The following potential conditions illustrated in detail in Figs. 5 and 6 result during operation of the inverter with symmetrical clocking" (my emphasis). And when Fig. 5 is introduced earlier (page 13, lines 1-2) it is stated that, "Fig. 5 shows equivalent circuit diagrams for explaining the potential behaviour in the inventively formed inverter" (my emphasis). From these passages I believe the skilled person would understand that the description of Fig. 5 refers to the "inventively formed inverter" that is described in relation to Fig. 1 (see page 12, lines 22-23 and page 13, line 19 – page 14, line 20). Secondly, I believe that the skilled person would also understand that Fig. 7 shows an example of operating the "inventively formed inverter" of Fig. 1. I believe that this would be understood from the passage the requester highlights (page 14, lines 15- 20) and also from Fig. 7 itself. I believe the skilled person would understand from the description of Fig. 7 (page 15, line 1 – page 16, line 4) that it is an example of the how the switches A, B, C, D, E and F in the topology of Fig. 1 are operated (e.g. as explained at paragraph 8 above). I believe that the skilled person would understand from pages 14-17 that Fig. 7 explains how switches A-F of Fig. 1 are operated in order to produce certain states of the inverter of Fig. 1 and that these states are represented by the equivalent circuits shown in Fig. 5 (e.g. as explained at paragraph 9 above). In particular, I believe that the skilled person would understand that when switch E is closed and switches A and D are open (page 15, line 30 – page 16, line 1) the equivalent circuit diagram of Fig 5b results (page 16, lines 11- 13). And when switch F is closed and switches B and C are open (page 16, lines 2- 4) the equivalent circuit diagram of Fig. 5d results (page 16, lines 13-14).

51. Thus, when reading the parent application, I believe the skilled person would understand that the equivalent circuit diagrams of Fig. 5 are not a general teaching to be read in isolation. Instead, I believe the skilled person would understand that Fig. 5 is an aid to understanding the operation of the "inventively formed inverter" of Fig. 1 (that is described in relation to Fig. 7).

- 46 The examiner has clearly considered the arguments of both the requester and the observer and reached a reasoned opinion that figure 5 would be read in conjunction with figure 1. He did not have the advantage of expert evidence on the matter nor did he benefit from the further explanation I had. Rather his opinion was based upon the evidence before him at the time and in light of that I believe that the opinion he

arrived at was reasonable. It was not clearly wrong or the result of any error in principle.

Conclusions

- 47 In respect of Opinion 02/17, I conclude that the examiner's stated opinion that claim 1 of the patent in suit lacks novelty over the MAKINO disclosure is not clearly wrong and there was no error in principle made. I accordingly make no order to set any part of the Opinion aside.
- 48 In respect of Opinion 15/17, I conclude that the examiner's stated opinion on a question of added matter in respect of claim 9 of the patent in suit is not clearly wrong and there was no error in principle made. I accordingly make no order to set any part of the Opinion aside.
- 49 I would add further that my decision not to set aside Opinion 2/17 leaves in place an opinion that has concluded that section 1(1)(a) (novelty) is not satisfied in relation to the patent. Hence under section 73(1A) the comptroller may revoke the patent on his own initiative. Such action is however only taken where the patent is deemed to be clearly invalid. In this instance I do not believe that that is the case and therefore no further action under section 73(1A) will be taken against the patent.

Appeal

- 50 Any appeal must be lodged within 28 days after the date of this decision.

Phil Thorpe
Deputy Director acting for the Comptroller